

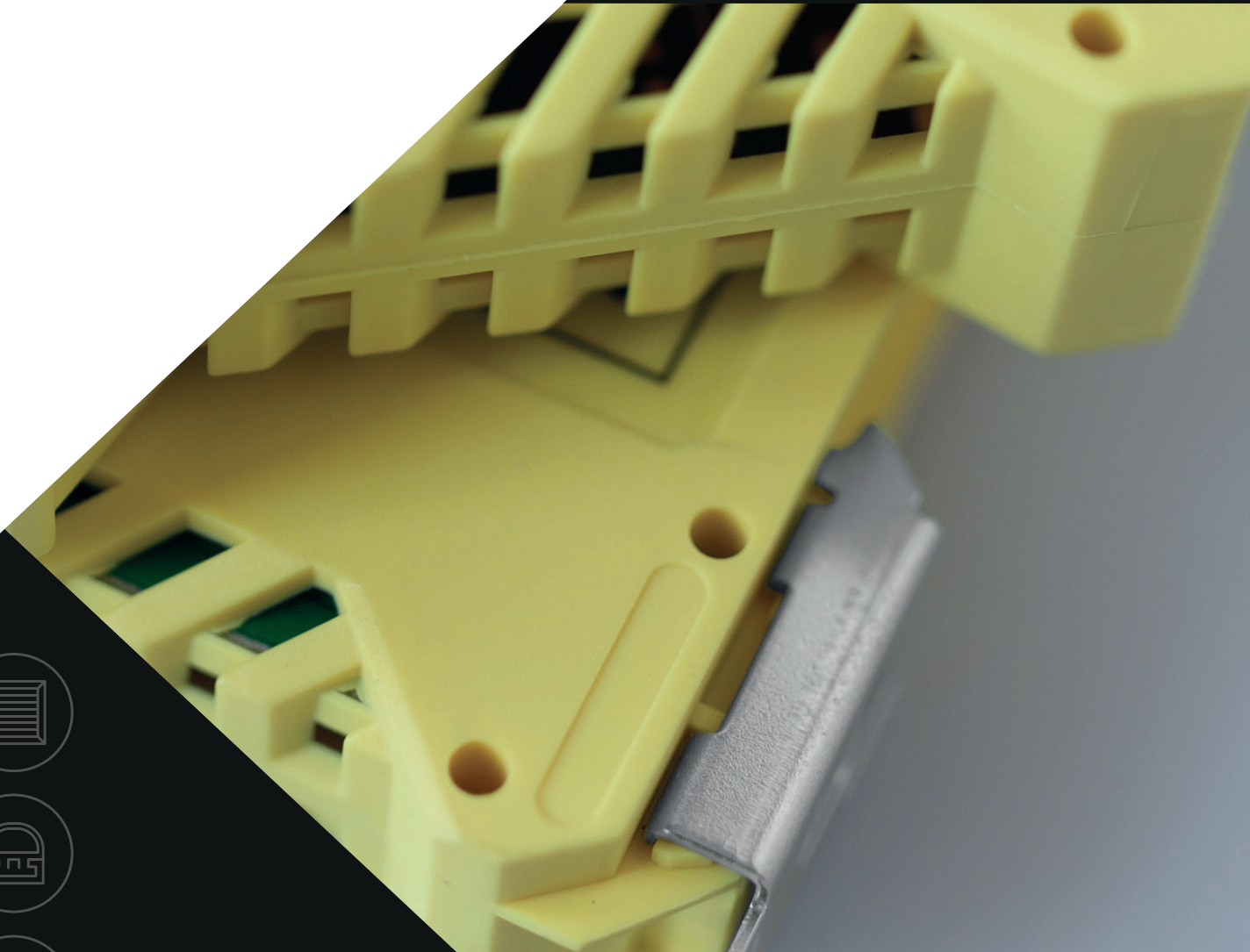

INSTALLATION AND SYSTEM DESCRIPTION

FOR SSZ CONTROL UNIT

TYPE SSZ-RZ3



MADE IN GERMANY

Thüringerstrasse 17, 46286 Dorsten

Tel: +49 236940 94

Fax: +49 23 69 - 2 15 97

Email: info@ssz-gmbh.de

Issue 2017, Version 1

This Operating Manual applies to control unit

- Type: SSZ- RZ3, Performance Level PL d (in system) Category 3, acc. to EN ISO 13849-1 to be connected to: SSZ-Safety Mats and SSZ-Safety Rails and SSZ-Safety Bumpers.

Response time < 20 ms

Reset function - automatic/manual

Control unit identification is provided with the number, printed on a hologram (on the housing).



For proper device identification, the Installer should write down the ID number from the hologram in the device identifying form!

Prior to installation, it is recommended to read with understanding all the contents of this Operating Manual, together with operating manuals of particular pressure-sensitive safeguarding products.

- SSZ safety mat instructions of use
- SSZ safety bumper instructions of use
- SSZ safety edge instructions of use

TABLE OF CONTENT

TABLE OF CONTENT	3	MAINTENANCE AND CONTROL OF PROPER FUNCTIONALITY	12
ABOUT THIS OPERATING MANUAL	4	STORAGE AND TRANSPORT	14
INTENDED USE	4	UTILISATION	14
SAFETY RECOMMENDATIONS	5	NOTES	14
CONTROL UNIT LABELLING	6		
MAINTAINED SAFETY LEVEL	6		
TECHNICAL PARAMETERS	7		
SAFETY UNIT FUNCTIONALITY TESTS	9		
CONNECTING OF SAFETY UNIT	10		
MOUNTING	12		

These instructions form is an essential part of the product.

These instructions contains basic information that must be noted when installing the system. It is important that the personnel familiarize themselves with these instructions before installation and commissioning. The following documents from the purchaser also apply in addition to these instructions:

- The drawing of the configuration (optional)
- The cable diagrams (optional)

ABOUT THIS OPERATING MANUAL

Keep the operating manual at accessible location during the entire service life of the product. This operating manual shall be passed onto any subsequent owners / users of the product. Any updates to the contents of the operating manual, received from the product manufacturer, shall immediately be included in this operating manual.



The control unit is a part of the system:

SSZ pressure sensitive safety products + a control unit. The system shall be connected to a machine by properly trained technical personnel only.

The technical personnel shall be familiar with assembly and mounting techniques, as well as with the functions of devices and systems.

This operating manual is valid only for the product specified on the title page. In addition to this operating manual, the following documents shall be followed:

- structure drawings of machine / device, remaining at the customer's disposal (optional),
- a schematic drawing of connection
- an assembly drawing of devices with SSZ sensor(s) - see Annex No. 1 to this operating manual.

INTENDED USE

SSZ-RZ3 control unit is intended to generate a safety-related signal for emergency stop of machines and other technical devices. The control units may also be used to generate warning signals of persons. The control unit is designed for analysis and control of two-channel elements of in an electric circuit, including SSZ safety edges, SSZ safety mats and SSZ safety bumpers.

In wires, including the voltage supply wire, constant monitoring



In no event shall the SSZ GmbH Company be liable for any damages arising from or being a consequence of the product usage not in compliance with the operating manual.

This operating manual is a part of the product



The target group of this operating manual includes the product end-user and properly trained personnel (operators), authorised to use the product.

Before use of the product, read thoroughly this operating manual.

covers: electric energy flow direction, short-circuits and crossed wires, in compliance with the constant current principle.

SSZ-RZ3 control units can be supplied either with 24 V AC/DC or with 230 V AC.

In either case, the polarity of connected wires is not important.

SAFETY RECOMMENDATIONS



Any changes shall be forbidden in control unit setting or structure.

Supply voltage control shall be ensured. The supply voltage must be equal to the voltage value on the rated plate.

REQUIRED SPACING

While performing assembly tasks in the electric cabinet, it is necessary to maintain proper distance from heat sources.

PROTECTION FROM SUNLIGHT

The electric cabinet shall be protected from direct sunlight.

TERMINAL CURRENT LOAD

Terminal current load shall be observed.

PROTECTION OF RELAY CONTACTS

The risk of welding together: the relay contacts beyond the connecting area shall be provided with an overcurrent protection with activation amperage equal to the maximal permitted current of relay contact. Do not overload SSZ-RZ3 and SSZ-RZB control units. The specified switching (load) current shall not be exceeded.

IN CASE OF ANY FAILURE, SWITCH OFF THE UNIT!

SSZ-RZ3 control unit shall be switched off in case of any failure or defects.

DO NOT USE THE CONTROL UNITS IN POTENTIALLY EXPLOSIVE (ATEX) ZONES

SSZ-RZ3 control unit can not be used in zones with explosion hazards (ATEX zones).

THE RISK OF INJURY FROM ELECTRIC SHOCK!

Before and during the mounting works of SSZ-RZ3 control unit, all the electric machines/devices to be connected must be switched off from voltage supply.

OPERATION FAILURE DUE TO OVERHEATING

A pressure-sensitive product (SSZ safety mat, SSZ safety edge or SSZ safety bumper) functions may be disturbed in result of control unit overheating. A safety unit shall be mounted in enclosures with IP54 as minimal protection index (e.g. in control cabinets).

TERMINAL ASSIGNMENT

Terminal assignment shall be observed when connecting the supply voltage

PROTECTION OF RELAY CONTACTS

Danger of contact welding Relay output shall additionally be external protected

DO NOT OVERLOAD CONTROL UNITS

It shall be ensured that contact current is not exceeded.

MAINTAINED REDUNDANCY

It shall be ensured that all connections are made within the circuit or that another control unit.



The machine shall not be switched on in case of any hazard! Failure to respect these recommendations may be hazardous to health or even life-threatening!

The CE declaration of conformity is not valid when devices or control units, other than SSZ, are connected.

THE SCOPE OF DELIVERY

1 x safety unit

An enclosure with an electronic module and plug-in connections

1 x operating manual

Immediately after delivery is received, it shall be checked for completeness and visual status.

CONTROL UNIT LABELLING

SSZ-RZ3

The control units correspond to category 3, Performance Level PLd - in compliance with EN ISO 13849-1.

NOTE: The control unit is a part of the system. SSZ a pressure-sensitive device + a control unit, PLd is the highest safety level for the entire system.

MAINTAINED SAFETY LEVEL

Any modifications nor installation of any other devices in the system is allowed. Only the SSZ control unit is an appropriate device to control the SSZ pressure-sensitive product. Any replacements of devices: of a control unit or of a pressure-sensitive product by a solution of other manufacturer pose risks of failure or malfunction of the entire system. Components may be replaced by the end-user. Replacement tasks shall be undertaken by properly trained technical personnel, with technical knowledge of machine/device assembly and functions.



The end-user shall independently determine the safety level of its application.



Safety category and level shall comply with the category and level of safety assurance, as determined by risk assessment.

TECHNICAL PARAMETERS

SSZ-RZ3 TESTING BASICS EN ISO 13849-1/2, EN ISO 13856 1-3

Nominal supply voltage SSZ-RZ3	24 AC/DC; 230 V
Allowable voltage	10.6 VDC - 36 VDC or 8 VAC - 24 VAC; 230V
Max. current consumption	290mA@12VDC; 135mA@24VDC; 250mA@24VAC
Rated current	100mA@24VDC
Power consumption P1	2,1 W
Internal fuse	1500 mA
Power circuit required fuse	2A
Working temperature range	0°C - +50°C
DIN Rail mount	Yes
Max. resistance of the sensor element channel 1 and 2	250kOhm
Max. resistance difference between the channels 1 und 2	20 %
Max. response time	< 20ms
Performance Level acc. to EN ISO 13849-1	PL=d (Pl e)*
The service life	287 years
MTTFd in connection with SSZ-presure equipment	74,1
DC (diagnostic coverage)	90%
CCF (common cause failure)	75
PFHd acc. to IEC/EN 62061 in connection with SSZ-Pressure equipment	4.33 ^{E-8}
The category acc. to IEC/EN 62061	SIL 2
Safety category acc. to EN ISO 13849-1:2016-02	3
Contact rating acc. to EN 60947-5-1	15 VAC (50/60Hz) - 3A 13 VDC - 3A
Min. switching current I ₁ channel 9-10/11-12	5V/10 mA
Max. switching current I ₂ channel 9-10/11-12	2 A
Mechanical endurance channel 9-10/11-12	>10 ⁷
Electrical endurance channel 9-10/11-12	>3,6 x 10 ⁵ (DC24V/1A)
Rated operational power	500mW
Reset	automatic/manual
Storage temperature [°C]	-10 - +50
Grade of protection acc. to IEC 60529:2003	IP30
Dimensions	112x23x99
Weight	180g



*SSZ-RZ3 unit is a part of the system:

SSZ-pressure-sensitive device in connection with SSZ-safety unit, therefore, despite PL e category, obtained by SSZ-RZ3 unit, the category has been decreased to PL d, following the safety evaluation rules, and this category shall be regarded valid because whole system has to be considered.

Prior to the system connection, the installer is obliged to read the operating manual of the proper equipment in use:

- SSZ safety mat instructions of use
- SSZ safety edge instructions of use
- SSZ safety bumper instructions of use



SSZ-CONTROL UNITS, IN COMBINATION WITH A PRESSURE-SENSITIVE DEVICE (SAFETY MATS, EDGES, BUMPERS) MAY OBTAIN THE HIGHEST SAFETY LEVEL OF PL d.

SAFETY UNIT FUNCTIONALITY TESTS

- Disconnect sensors on terminals 3, 4, 5 and 6. Short terminals 3 and 5 with one wire and terminals 4 and 6 with another.
- After supply voltage is on red and the two green control LEDs shall be illuminated and the output relays shall become active.
- If terminals 3 and 4 or 5 and 6 are shorted, then both channels shall be inactivated: the green LEDs shall be off, while the red LED shall be illuminated. (Simulation of the SSZ pressure sensitive equipment activation)
- If the connection of terminals 3/5 is broken, the K1 relay shall be inactivated. (Simulation of the broken cable).
- If the connection of terminals 4/6 is broken, the K2 relay shall be inactivated. (Simulation of the broken cable).
- In manual reset, when terminals 3 and 5 and 4 and 6 are shorted, only the red LED shall be illuminated. In order to activate the K1 and K2 relays, press the reset button on connected the RR terminals..

SAFETY UNIT TERMINALS

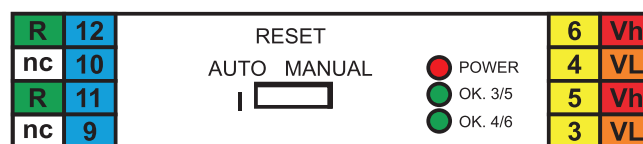

Safety unit terminal	SSZ-RZ3 24V AC/DC	SSZ-RZ3 230V AC
3	SSZ-Sensor, terminal 3	
4	SSZ-Sensor, terminal 4	
5	SSZ-Sensor, terminal 5	
6	SSZ-Sensor, terminal 6	
9	Relays output	
10	Relays output	
11	Relays output	
12	Relays output	
R	RESET button	
R	RESET button	
Vh	L (230V AC)	
Vh	N (230V AC)	
VL	+24V AC/DC	
VL	0V	



The SSZ-RZ3 control unit is factory set to operate with automatic reset.

CONNECTING OF SAFETY UNIT

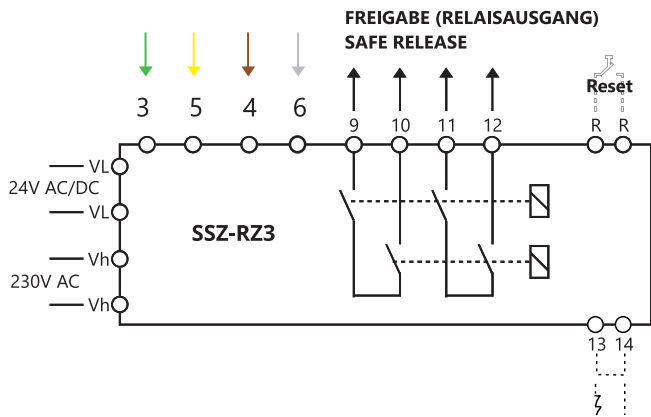

If the RESET switch is in position "I", the safety unit works in the automatic reset mode. If the Reset switch is in position "0" the SSZ-Control unit works in manual reset mode. In this case the Reset button connected on Terminals RR shall be pressed and released. To avoid any manipulation of the system the acknowledgment follows after release of the before pressed Reset button. The SSZ-RZ3B will be released after double acknowledgment of the pressed before Reset button.

Reset	options: automatic or via an external button, closing the R-R circuit
Sensor	terminals 3, 5, 4 and 6
Colours of cables	3 = green 5 = yellow 4 = brown 6 = white
Colours in case of safety mats with connector	3 = blue 5 = black 4 = brown 6 = white
Safety circuit	9-10 and 11-12

SCHEMATIC PRESENTATION OF THE SAFETY FUNCTION BETWEEN SSZ-CONTROL UNIT AND THE MACHINE CONTROL SYSTEM.

The output contacts of the control unit, serially connected, shall be integrated with the machine emergency switch circuit. Unless the pressure-sensitive device is activated, the relay contacts, i.e., also the emergency switch circuit, are closed. When the pressure-sensitive device is activated, the relay contacts of the control unit are opening, what stops the risk posing run of the machine.

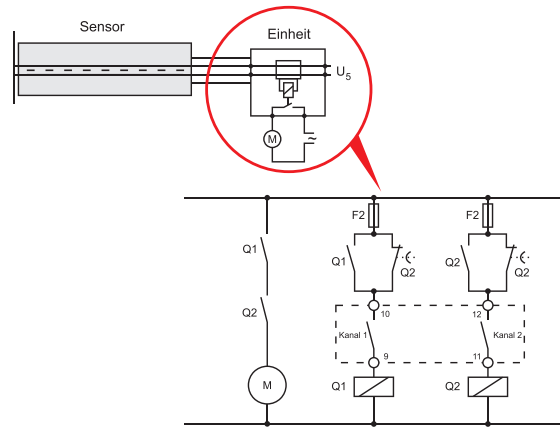

Fig. Example of connection to machine control system with the use of an SSZ-RZ3 control unit

Additional examples for each control units shall be available in the operating instructions of a given control unit.



The safety of machine and proper functionality of the safety pressure devices depends on the correct installation of mutual connections.

SSZ-RZ3/RZ3B CONTROL UNIT CONNECTION TO MACHINE OPERATING SYSTEM

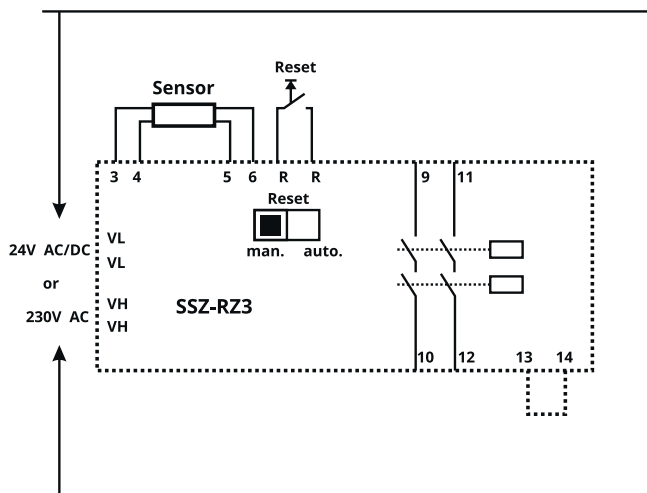

Safe stop by intern contacts in manual reset

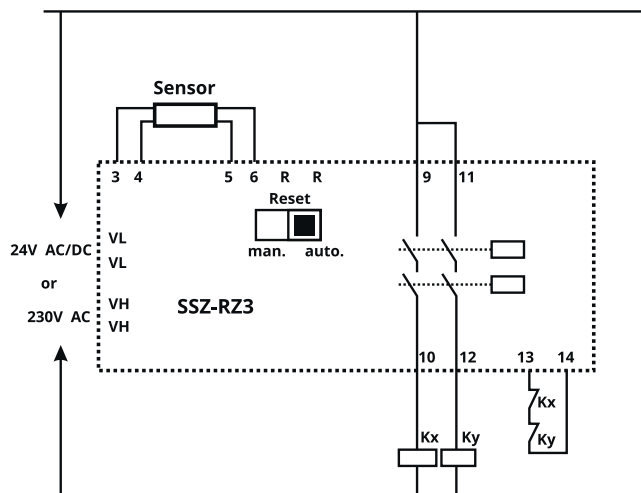

Safe machine stop by external devices in automatic reset

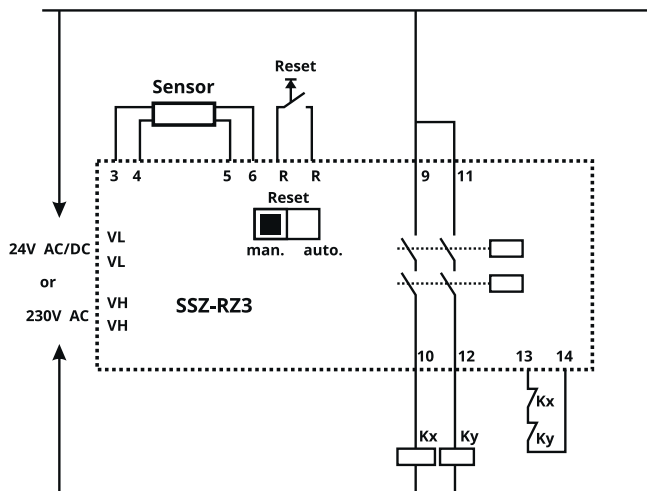

Safe stop by external devices in manual reset

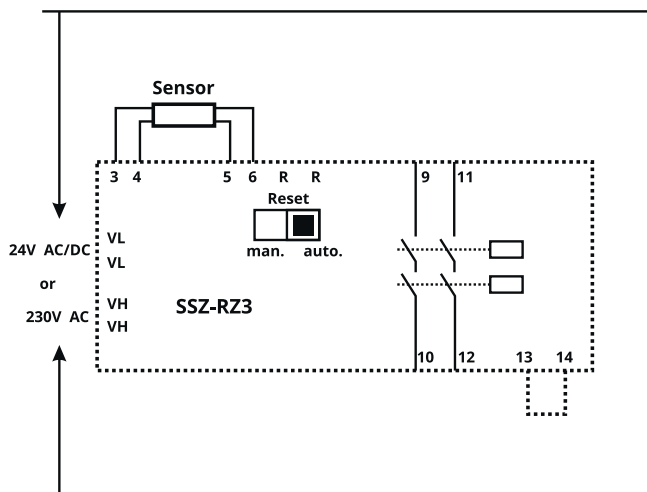

Safe stop by intern contacts in automatic reset

MOUNTING

Safety units of SSZ-RZ3 type are mounted on a DIN 35 mm rail, see the drawing below.

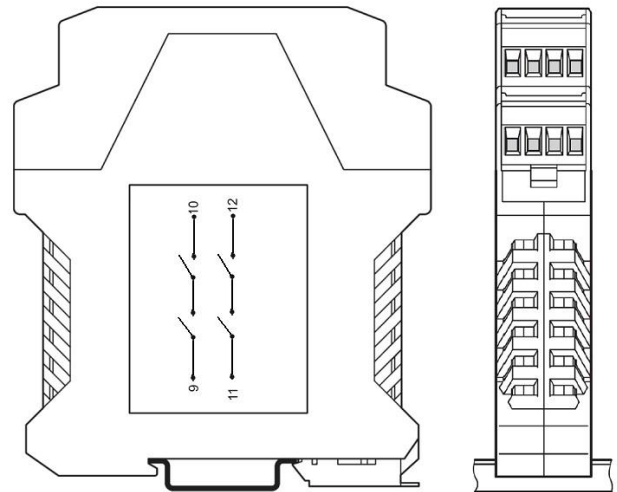

MAINTENANCE AND CONTROL OF PROPER FUNCTIONALITY



Danger of electric shock!

The functional tests of control units shall be carried out daily.

- Prior to any maintenance works, disconnect the control unit and the connected devices from the electric supply and protect them against unintentional activation.
- Check if no voltage is present on any part or component.
- Clean the housing on the outside with a clean cloth.

AUTOMATIC RESET CONTROL FOR SSZ-RZ3 AND SSZ-RZ3B UNIT

The control unit is provided with an automatic reset function. In a pressure-sensitive device is released, then K1 and K2 relays will immediately return to their baseline position, switching the control unit to standby mode.

PROPER FUNCTIONALITY CONTROL FOR SSZ-RZ3 AND SSZ-RZ3B UNIT: AUTOMATIC RESET CONTROL

1. Make sure that no SSZ pressure-sensitive device is activated.
 - the "OK 3/5" and "4/6 OK" green LEDs are on
 - The Relais contacts K1 & K2 are closed
2. Press the SSZ device
 - the "OK 3/5" and "4/6 OK" green LEDs are off
 - The Relais of K1 and K2 are open
 - Release the pressure-sensitive device (do not press)
 - the "OK 3/5" and "4/6 OK" green LEDs are on
 - The relais contacts K1 and K2 are closed



Before re-start of the unit, check it for proper functionality!

Manual reset control for SSZ-RZ3 unit

1. Press the SSZ-pressure-sensitive device
2. Make sure that no one of the SSZ pressure sensitive devices is pressed
 - The green LED`s "OK 3/5" and "4/6 OK" are off
 - The relais contacts of the channel K1 & K2 are opened
3. Press the reset button
 - The "OK 3/5" and "4/6 OK" green LEDs are on
 - The relais contacts of the channel K1 & K2 are closed
4. Press the SSZ pressure-sensitive device
 - The "OK 3/5" and "4/6 OK" green LEDs are switch off
 - The relais contact of the channel K1 & K 2 are opened
5. Unlock the pressure-sensitive device
 - The "OK 3/5" and "4/6 OK" green LEDs are switched off
 - The relais of the contacts channel K1 & K2 are opened
6. Press the reset button, while the pressure-sensitive device should not be pressed
 - The "OK 3/5" and "4/6 OK" green LEDs are switched on
 - The relais contacts of the channel K1 & K2 are closed
 - The SSZ-pressure-sensitive device is unlocked and ready for operation



Do not switch on the machine as long as there is any risk!

Periodical inspections of the control unit should be carried out at least twice a month, while the functionality of signalling lights – LEDs – should be a subject of daily control. The frequency of the inspections should be estimated appropriate to the safety function activations

The SSZ-control unit check shall include:

- Visual check of the housing for possible damages.
- Exclusion of possible manipulations. The SSZ hologram shall remain intact.
- Operation and functionality check executed acc. to this Operation Manual.
- Checking the correctness of the installation in the electric box.
- Ensuring the correctness of connection to machine or device

After completing the assembly and function requirements the system may be approved for use, according to the applicable standards and regulations of the country of use.



The user may replace parts, using exclusively their equivalents approved by the manufacturer! Any modifications or installations of other components / devices in the system shall be prohibited. The SSZ control unit shall be the only device suitable for control of SSZ sensitive devices. Replacing SSZ control unit or pressure-sensitive devices by products of other vendors poses a risk of functionality failure or total collapse for the entire system!



No spare parts for the above-mentioned system. In case of any failure, replacement parts shall be sought from the manufacturer, including the control unit, the cable, the aluminium profile or the pressure-sensitive device.



In order to ensure proper functionality of a pressure-sensitive protective device, as well as its installation, adhering to the requirements of EN-ISO 13849-1-2 and EN ISO 13856-1-3 : 2013-1, the technical personnel shall be familiar with assembly techniques, as well as with gear and systems, supported by training at the SSZ-GmbH Company or at an agency, designated for the purpose by the manufacturer.

In case of any technical problems, it is recommended to contact the manufacturer or any responsible agency, representing the manufacturer at a given country. See the manufacturer's home-page www.ssz-gmbh.de for the actual list of representatives.

Acceptance procedure

1. Pressure-sensitive device assembly and functionality check acc. to the requirements in the Operation Manual of the chosen SSZ pressure sensitive device .
2. Checking for correct cabling from the control unit to the SSZ pressure sensitive device; a particular attention shall be paid to redundancy preservation in the system!
3. Checking of the safety function– acc. to the safety documentation.
4. Measurement of the entire system's response time and "full time stop", as well as functionality(lock or release) check, caused by the activation of an SSZ pressure-sensitive device. The results should be compared to the specification requirements. All results should be written into the documentation of the machine.
5. A special attention shall be paid to the signalling system in the SSZ control unit (one red and two green LEDs), indicating either normal operation or failure of the system!

If none of the LEDs is active, the supply of the control unit should be checked. If the supply connection to the control unit is correct, while its functionality still fails, it is necessary to contact the manufacturer.

The same acceptance procedure shall be valid when particular, individual components are replaced (either of SSZ pressure-sensitive device or a replacement of the SSZ control unit)

The installer shall be obliged to fill in an identification form of an installed device. In order to ensure a correct identification, please enter in the form, the number from the hologram on the pressure-sensitive device and on the SSZ control unit.



The system does not have an auto-check function. According to the level of safety assurance- PLd , the system in the standby mode is controlled by the unit.

The applied prevention measures against systematic defects (EN ISO 13849-1: 2015))

- The design of the devices ensures protection in case of supply voltage loss. The output relays become disconnected, i.e., the electric circuit in open on the output relay contacts.
- In the supplying branches of measurement circuits, integrated, voltage stabilisers are applied which, together with capacitive filters, considerably protect against input voltage variations.
- The input resistive measurement system has been designed to eliminate as much as possible errors, resulting from unstable supply voltage.
- The applied output relays, designed for use in safety devices, are subject of internal control.
- The design configuration of SSZ safety units has for years been used in thousands of applications and is also used in other, manufactured by us devices.
- Control unit SSZ-RZ3 has been designed in line with the EU's engineering pattern and checked and approved with regards to electromagnetic compatibility, ventilation, cooling and vibrations.
- The SSZ-GmbH Company has for more than 25 years been carrying out internal quality control in its full scope, i.e., including particular elements and their documentation.
- The same team of qualified employees participates in the production process.
- The parts and components in the devices originate from proven, recognised manufacturers with appropriate certificates.
- The Company enjoys a more than 25-year tradition and experience, represented all over the world, while in some European countries, SSZ products are market leaders.

STORAGE AND TRANSPORT

SSZ-RZ3 and SSZ-RZ3B control units shall be stored and transported in their original, manufacturer's packaging, protecting them from damage. The units are individually packed in carton boxes, together with operating manuals.

The units shall be stored at indoor, dry premises, the relative humidity of which shall not exceed 80%. The ambient air temperature shall not exceed the range from -10°C to 70°C. Protection grade of control unit enclosure against external factors: IP 30

UTILISATION

The devices, manufactured by the SSZ GmbH Company, are professional electronic solutions, designed exclusively for industrial applications (so called, B2B devices). Unlike the commonly used household utilities (B2C), B2B devices must not be disposed to-

gether with municipal waste. When the service life of a B2B device expires, it can be returned to the SSZ GmbH for proper utilisation.

NOTES



Safety units are only a part of safety system - design and construction of a safety system shall be based on the rules and provisions, contained in standards and in the machine directive.



Rated load values on outer contacts shall not be exceeded.



All external cable feeds shall be protected against excessive loads and led in insulating sleeves.



All electric connections shall properly be tightened and checked. Periodical checks of electric terminals shall be scheduled.



Ssz units shall be mounted exclusively in electric cabinets. The required protection degree shall be observed.



Opening the SSZ - control unit box may lead to the loss of the system safety. Under no circumstances shall the devices be opened. Any hologram breach shall make the guarantee void.



If a defect/failure occurs, such a unit shall be returned to the manufacturer for repair.



Before any unsafe machine task, the safety system functionality shall be checked, if possible. The functionality check involves ssz safety unit activation and confirmation that a dangerous machine run has been stopped.



Regardless of the circumstances, the occupational safety rules, as well as other appropriate regulations shall be adhered to. Failure to do so may pose hazards for health and life.



Sicherheits-Systeme
Zimmermann GmbH

A: Thüringerstrasse 17, 46286 Dorsten-Wulfen

T: + 49 2369/4094

F: + 49 2369/21597

E: info@ssz-gmbh.de

W: ssz-gmbh.de

ALL RIGHTS RESERVED
Version 2017